

(No Model.)

2 Sheets—Sheet 1.

C. R. PENFIELD.
CUTTER HEAD.

No. 448,254.

Patented Mar. 17, 1891.

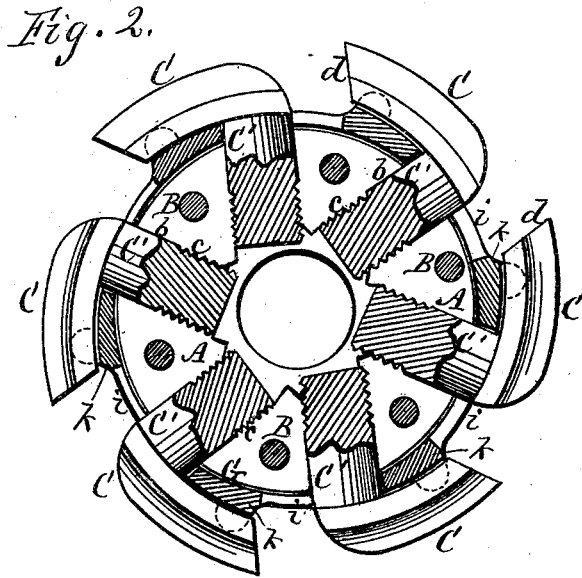
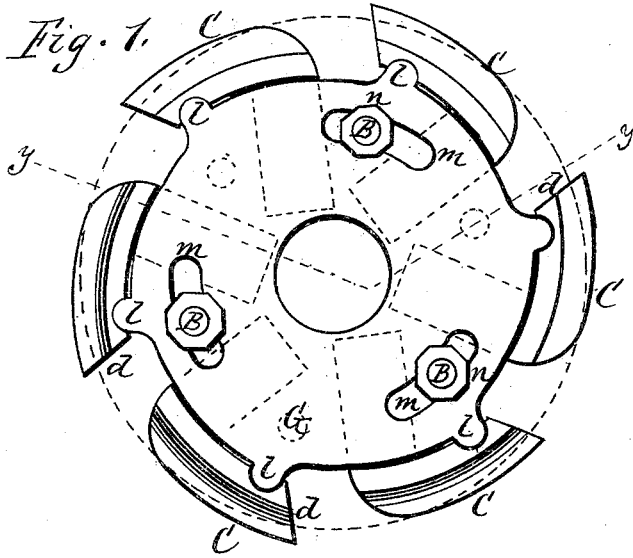

Witnesses

Paris Clark
John A. Hopkins

Chas R. Penfield Inventor

By *his Attorney*
R. F. Osgood.

C. R. PENFIELD.
CUTTER HEAD.

No. 448,254.

Patented Mar. 17, 1891.

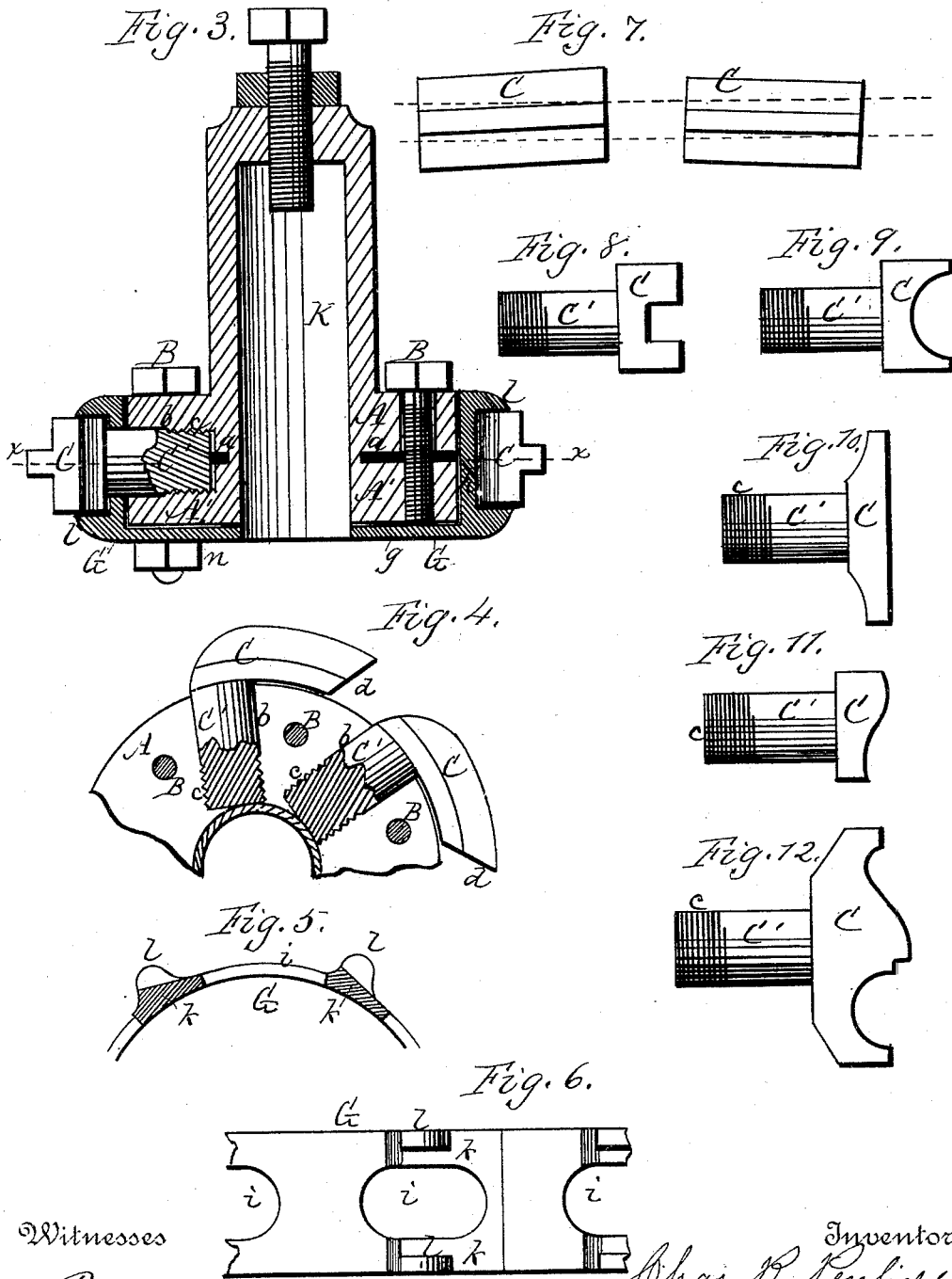

Witnesses

Chris Clark
John H. Hopkins

Inventor
Chas. R. Penfield.
By his Attorney
R. F. Osgood.

UNITED STATES PATENT OFFICE.

CHARLES R. PENFIELD, OF LANSING, MICHIGAN.

CUTTER-HEAD.

SPECIFICATION forming part of Letters Patent No. 448,254, dated March 17, 1891.

Application filed February 1, 1890. Serial No. 338,942. (No model.)

To all whom it may concern:

Be it known that I, CHARLES R. PENFIELD, of Lansing, in the county of Ingham and State of Michigan, have invented a certain new and useful Improvement in Cutter-Heads; and I do hereby declare that the following is a full, clear, and exact description of the same, reference being had to the drawings accompanying this application.

My improvement relates to cutter-heads for matching lumber, dressing moldings, and for similar uses; and it consists in the construction and arrangement of parts hereinafter described and claimed.

In the drawings, Figure 1 is an end view of my improved cutter-head. Fig. 2 is a central horizontal section of the same in line xx of Fig. 3. Fig. 3 is a central vertical section of the same in line yy of Fig. 1. Fig. 4 is a diagram showing a central horizontal section of a portion of the head and two of the knives resting therein, said knives being reversed or turned in the opposite direction from their position in cutting and designed to exhibit the method of finishing the knives in an engine-lathe preparatory to use. Fig. 5 is a horizontal section of a portion of the guide band or case that surrounds the head. Fig. 6 is a plan view of Fig. 5. Fig. 7 is a diagram showing a plan view of two of the grooving-knives and exhibiting the alternating offset position of the points of said knives to prevent binding in cutting the lumber and provide clearance in operation. Figs. 8, 9, 10, 11, and 12 are views showing different forms of the knives.

The cutter-head is composed of two parts A and A', which are divided by a cleft a , that extends nearly or quite through to the center, thus making the head in the form of a clamp, the two parts of which are united by clamp-screws B B B. The rim of the head is provided with a series of round holes $b b$, formed partially in each half of the head to receive the round shanks of the knives, and the inner ends of the holes are provided with screw-threads to receive corresponding screw-threads on the shanks.

C C are the knives, provided with cylindrical shanks C' C', which enter the round holes $b b$ in the head and are held fast by the clamp-screws that pass through the head. The

inner ends of the shanks have screw-threads $c c$, which enter the internal threads of the holes $b b$, as before described. The shanks are located at an acute angle to the cutting-blades, as shown. This angle is determined by the diameter of the head, the object being to enable the knives to be turned up and dressed on the same head in which they are afterward used. To do this the knives are turned to the position shown in Fig. 4—that is, the points are turned in the reverse direction from that in which they run in use. In this position the inner sides of the cutters rest close to the head and the outer sides form a true circle concentric with the head itself. When the cutters are thus arranged, the cutter-head can be placed in an engine-lathe and all the cutters be turned up and finished at one operation. After being thus finished the cutters are turned half-way around to bring them in the reverse position for use and the points stand out like saw-teeth, as shown in Figs. 1 and 2. The shanks might radiate from the center; but in such case the cutters would have to be turned up and dressed on a head made for that special purpose. The cutting-points of the knives are beveled inward, as shown at $d d$. By this means the knives can be sharpened by holding the beveled edges to an emery-wheel, the grinding being done on the beveled edge only. Harder cutters can be used than those ordinarily employed, and they will therefore wear much longer before being resharpened.

Various forms of cutters may be used, according to the work to be done. Figs. 1, 2, and 3 show grooving cutters for matching boards. Fig. 8 shows the corresponding cutter for tonguing boards. Fig. 9 shows a cutter for forming a half-round on a rod or other piece. Fig. 10 shows a straight-edger. Fig. 11 shows an ogee-edger, and Fig. 12 one form for cutting moldings.

Cutters of any desired shape and any purpose where lumber is to be fashioned and dressed may be employed.

The points of the tonguing-and-grooving knives are set in the alternate position shown in Fig. 7—that is, they are slightly offset at opposite points, so that in action they cut a tongue or groove somewhat wider than the cutters themselves. This gives clearance back

of the points of the knives and prevents in a great degree the friction that occurs by a close contact of the sides of the knives with the sides of the wood. Said sides are entirely removed from contact with the wood.

G is a guard consisting of a case provided with a face-plate *g*, that covers one end of the cutter-head, and a rim *h*, that embraces the periphery of the head. Holes *i i* are made in the rim to allow passage of the cutter-shanks *C' C'*, and these holes are elongated, as shown in Figs. 5 and 6, to allow a degree of turning movement to the guard, for a purpose presently to be described. Back of each of these holes is a lug *k* of greater thickness than the body of the rim and gradually tapering away from the holes. On each side of these lugs are vertical tongues *l l* at such a distance apart as to allow the knives *C C* to rest between them.

When the cutter-head is fitted for work, the guard *G* is turned back, so that the tongues *l l* embrace the sides of the cutters, as shown in Fig. 1, and the lugs *k k* rest in and fill the angular spaces under the cutters and next to the head. The guard is held in position by three of the clamping-bolts *B B B*, which pass through concentric slots *m m m* of the guard and have nuts *n n n* on their ends. The slots are of sufficient length to allow the necessary turning movement of the guard.

The lugs *k k* by filling the angular spaces under the cutters prevent the lodgment of chips and dust at those points, and therefore prevent clogging and irregular action. They also give stiffness and strength to the cutters and prevent trembling. The tongues *l l* by embracing the cutters keep them always in line and prevent any accidental turning to the right or left. Whenever it is necessary to turn the cutters or remove them the guard can be turned to relieve the tongues from the cutters and they can then be turned or removed without difficulty.

K is the hollow hub by which the cutter-head is attached to the operating-mandrel.

By the use of a divided cutter-head with round holes for holding cutters with round shanks, such as described, said shanks can be tightened or loosened in a few moments' time. The screw-threads on the ends of the shanks enable the cutters to be adjusted outward at any time to compensate for wear or the grinding away of points. To adjust them it is only necessary to loosen the guard *G* and then give one or more turns to the cutter-shanks to screw them out. These screw-threads also prevent the cutters from being thrown out of the head or becoming loosened by the centrifugal action under rapid motion. By this special construction a greater number of cutters can be inserted in the head, and therefore more rapid work can be done than by ordinary cutter-heads.

Having described my invention, what I claim as new, and desire to secure by Letters Patent, is—

1. The combination of a cutter-head composed of two parts and provided with round holes in its periphery, a set of cutters provided with cylindrical shanks resting in said holes, and clamping-screws passing through the head and clamping the parts of the same to the cutter-shanks, as herein shown and described.

2. The combination, with a cutter-head composed of two parts and having round holes in its periphery, of a set of cutters having cylindrical shanks resting in said holes, the ends of the shanks and the inner ends of the holes having screw-threads which fit together, and a set of clamping-screws passing through the head to clamp the parts together, as herein shown and described.

3. The combination, with a circular cutter-head composed of two parts and provided with round holes arranged tangentially to the axis of rotation, of a set of cutters with cylindrical shanks fitting in said holes and standing at an acute angle to the cutter-head, whereby when said cutters are set in reverse positions from their position in use they form a true circle at their periphery, as herein shown and described.

4. The combination, with a circular cutter-head and a set of cutters provided with cylindrical shanks that rest in round holes of said head, of a guard consisting of a band which encircles the head, provided with elongated holes for the passage of the cutter-shanks and with filling-lugs which rest under the cutters and between them and the head, as herein specified.

5. The combination, with a circular cutter-head and a set of cutters provided with cylindrical shanks that rest in round holes of said head, of a guard consisting of a band which encircles the head, provided with elongated holes for the passage of the cutter-shanks and with tongues on opposite sides which embrace the sides of the cutters to hold them in position, as herein specified.

6. The combination, with a cutter-head having round holes in its periphery, of a series of knives consisting of segmental cutting-blades and cylindrical shanks adapted to fit in holes of the cutter-head, whereby the cutting-points can be set in alternately offset positions by turning the cutters on the axes of the shanks, as herein shown and described.

In witness whereof I have hereunto signed my name in the presence of two subscribing witnesses.

CHARLES R. PENFIELD.

Witnesses:

FRANKLIN S. PORTER,
FRANK E. ROBSON.